



PRODUCTS & SERVICES OF THE FORUM TERATEC 2013 EXHIBITORS

During these two days, there will be an exhibition covering the whole HPC industry. Systems manufacturers and software vendors, integrators and distributors, service providers, academic and laboratory researchers, public and private sector developers will present their latest HPC innovations.

- [Exhibitors list](#)

ACTIVEON - ALINEOS - ALLIANCE SERVICES PLUS - ALLINEA SOFTWARE - ALTAIR ENGINEERING - ALTRAN - ALYOTECH - ANSYS France - BARCO - BULL - CAPS ENTREPRISE - CARRI SYSTEMS - CEA - CLUSTERSVISION - COMMUNICATION & SYSTEMES - DATADIRECT NETWORKS - DELL - EMC - ENGIN SOFT - ESI GROUP - EUROTECH - EXASCALE COMPUTING RESEARCH LAB - FUJITSU - GENCI - HEWLETT PACKARD- IBM - IFPEN - INRIA - INTEL - IRT SYSTEMX - KALRAY - NAFEMS - NETAPP - NICE SOFTWARE - NVIDIA - OPENSIDES - OXALYA - PANASAS - RITTAL - ROGUE WAVE - SCILAB - SGI - SILKAN - SOGETI HIGH TECH - ST MICROELECTRONICS - SYSPERA - SYSTEMATIC - SYSTEMX IRT - TERATEC - TOTALINUX - TRANSTEC

Here is a first outline of the products and services which you'll find "in live" on the show:

ALINEOS

■ Stand 39

■ Contact presse: Fabien DEVILAINÉ
Tel: +33 (0) 1 64 78 57 65
Mel: info@alineos.com

ALINEOS: Expert for Scientific Computing

Since the creation, more than 600 HPC clusters (integrating until several thousand cores) have been installed by ALINEOS in the major European research centers and laboratories, as well as in public and private sectors. In 2012, the company has strengthened its sales and technical teams by creating a department dedicated to industrial customers.

Thanks to that, it benefits today from resources enabling ALINEOS to guide its customers in their HPC projects and disposes of its own datacenter hosting servers and clusters (Calcul on Demand and Benchmark).

Aiming at providing high-performance scientific computation solutions at the leading edge of technology,

ALINEOS will present the new Phi 5110P card during the 2013 Teratec exhibition.

Based on the Intel® MIC Architecture, the Intel® Xeon Phi™ coprocessor easily extracts performance from highly parallel applications. These cards will be exposed in efficient hybrid platforms proposed by Supermicro, HP and Fujitsu manufacturers. You can test it on your own application upon request.



ALLIANCE SERVICES PLUS, GROUPE EOLEN

■ Stand 31

■ Contact: Dominique BEDART, Directeur d'Agence
Tel. : +33 (0) 1 46 12 00 00

Design, deliver and optimize your technological solutions for full exploitation of the opportunities offered by HPC.

AS+ will be your consulting partner to support your initiative and devise customized and efficient technical solutions.



CONSULTING & EXPERTISE

At the vanguard of technology, our experts share with our clients a valuable know-how on development, optimization and parallelization of calculation codes, ensuring a sustainable relationship based on trust and quality.

TURNKEY SOLUTIONS

The experience of GROUP EOLEN in the design and the

implementation of turnkey solutions supports our HPC team in the elaboration of offers dedicated to supercomputing.

TRAINING

As a partner of world-famous technological companies, AS+ offers a full range of training - multi-core architectures, GPU, hybrid... - allowing you to take full advantage of the latest innovations dedicated to cluster and embedded systems.

R&D

Our participation in R&D (FUI, FSN, ANR) alongside our partners in industry and academia guarantees our high level of expertise.

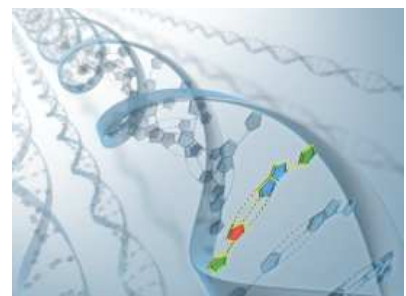

ALLINEA SOFTWARE

■ Stand 13

■ Contact Presse: Jacques PHILOUZE
Tel: +33 (0) 609 76 80 14
Mail: press@allinea.com

Allinea Software is recognized as the leading vendor of tools for parallel software development, offering the most complete toolset for parallel debugging and profiling. This unified platform provides an easy-to-use environment for:

- Each stage of development, from concept to production
- Every platform, with native clients for OS/X, Windows and Linux
- Today's and tomorrow's systems: CUDA, Xeon Phi, MPI, OpenMP, UPC, OpenACC and more

Powerful diagnostic capability, intuitive graphical interface and lightning performance - even on the largest systems - combine to make **Allinea DDT** the preferred debugger for users in research, academia and industry in the US, Europe and Asia.



Allinea MAP is an MPI profiler that just works, without slowing down your program. It shows you which lines of code are slow and gets everything else out of your way. There is no need to instrument your code or remember arcane libraries and settings. Allinea MAP works, out of the box, whether at one process or ten thousand, with just 5% overhead.

Jacques Philouze, Worldwide Vice President of Sales and Marketing, and his team will be presenting and exhibiting at the Teratec Forum. He said, "Our tools have been proven time and time again at varying scales to save time, lower costs and boost productivity. We are now releasing version 4.1 – visit our stand to see the tools in action."

ALTAIR ENGINEERING

■ Stand 42

■ Contact Presse: Krista COJOCAR, Marketing, Creative Manager
Mel: krista@altair.com
www.pbsworks.com - www.altair.com

Altair empowers client innovation & decision-making through technology that optimizes the analysis, management & visualization of business & engineering information. We are the only company to offer best-in-class application software, HPC workload management tools & a licensing model for growing computing needs. Privately held, Altair has a 27+ year track record for high-end software & consulting services for engineering, computing & enterprise analytics worldwide.

PBS Works™, Altair's suite of on-demand HPC cloud solutions, allows enterprises to maximize ROI on existing infrastructures. It is the most widely implemented software for managing grid, cloud & cluster computing resources.

PBS Works suite includes:

- **PBS Professional**[®] optimizes the world's largest supercomputers, including many supercomputing sites within the Top500, providing max. security, reliability & energy-efficiency.
- **Web portals:**
 - **Compute Manager**[™] allows users to run, monitor, and manage workloads on distributed resources. Its results & remote visualization capabilities enable working with Big Data efficiently and securely.
 - **Display Manager**[™] enables seamless remote visualization of Big Data, preventing large data movement across networks for optimized performance.
 - **PBS Analytics**[™], a job accounting / reporting solution, provides administrators with advanced analytics to support data-driven planning.



ALYOTECH TECHNOLOGIES

■ Stand 12

■ Contact Presse: Stéphane MALLEDANT
Tel: +33 (0) 2 23 21 11 11 / +33 (0) 6 63 74 11 29
Mel: stephane.malledant@alyotech.fr

MERCUDA : simulating marine operation scenarios.

Monitoring sea borders is today a major challenge for Defence and National Security. The aim of surveillance, observation and identification systems is to detect, follow and identify increasingly furtive threats in increasingly complex environments.

Perfecting these systems requires huge quantities of observation data about the marine environment. Given the cost, variability and complexity of sea trials, digital simulation provides a flexible and cheaper alternative. To meet this need, Alyotech has developed MERCUDA, a high-performance software package for simulating marine operation scenarios.

Multi-sensor tool, MERCUDA is both realistic and fast enough to provide industrialists with real time lifelike marine scene simulation software.

It is a tool which assists with decision-making from the sizing and design phases to assessing the performance of surveillance and maritime security systems.

MERCUDA is a complete solution for simulating marine operation scenarios including configurable objects (coast, infrastructures, vessels, means of observation, etc).



The data, obtained in real time thanks to the implementation of GPU, enable users to reduce costs by perfecting observation systems (qualification, sizing, assessing performance) and quickly producing a large number of contexts of use.

Users can simultaneously manage images and signals for different types of sensors (fixed or mobile) and in different spectral bands (radar, visible, IR).

ANSYS FRANCE

■ Stand 32

■ Contact Presse: Sabine MAÏDA
Tel: +33 (0) 1 30 60 15 00
Mel: sabine.maida@ansys.com

"ANSYS: Built for HPC"

As the acknowledged industry leader in engineering simulation, ANSYS has made a commitment to offer a comprehensive suite of solver and HPC advancements across the entire range of physics. Whether your focus is on structural, thermal, fluids or electromagnetic analysis — or the complex interactions of multiple physical.

ANSYS® technology enables highly scalable HPC deployment, giving you virtually unlimited capacity for high-fidelity simulation and the detail it provides. You can launch our HPC solutions within a workgroup or across a distributed enterprise — whether using local workstations, department clusters or enterprise servers — wherever your resources and people are located.

For ANSYS software to effectively leverage today's hardware, efficient execution on multiple cores is essential. ANSYS continues to release consistent, significant solution improvements, developed specifically to sustain speed and scaling on the latest HPC workstations, servers or clusters.

The various ANSYS HPC licensing options allow scalability to whatever computational level a simulation requires, from small user group options to enable entry-level parallel processing up to virtually unlimited parallel capacity. For large user groups, ANSYS facilitates multiple parallel processing simulations, highly scalable for the most challenging projects when needed.

Our HPC tools intelligently distribute complex problems across multiple CPUs and GPUs, leading to the fastest, best possible solution.

- ANSYS HPC Packs
- ANSYS HPC Workgroup
- ANSYS HPC Enterprise
- ANSYS HPC Parametric Pack
- ANSYS Electronics HPC

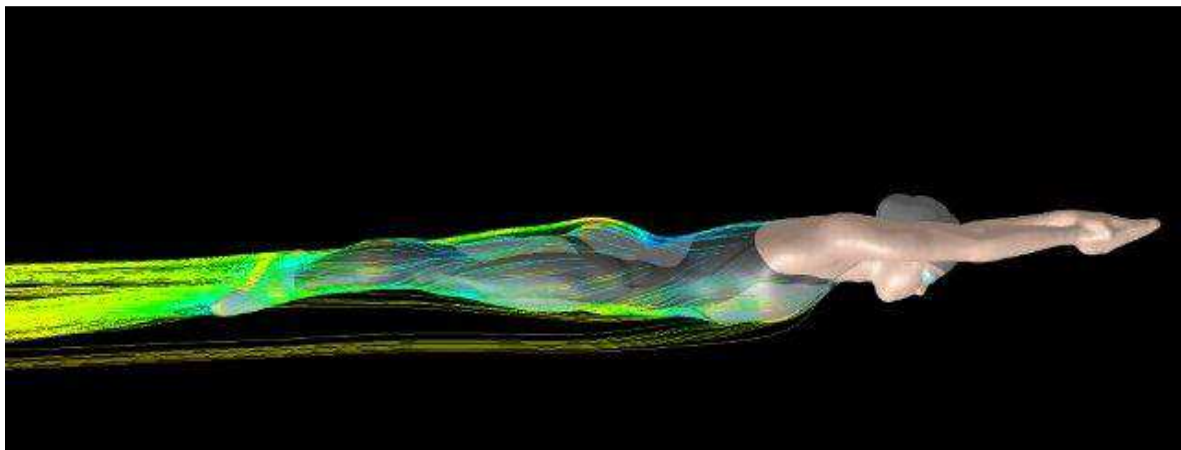

■ Contact Presse: Aurélie NEGRO
Tel: +33 1 58 04 05 02
Mail: aurelie.negro@bull.net

Bull is a leader in secure mission-critical digital systems.

The Group is dedicated to developing and implementing solutions where computing power and security serve to optimize its customers' information systems, to support their business.

Bull operates in high added-value markets including computer simulation, Cloud computing and 'computing power plants', outsourcing and security. Currently Bull employs around 9,000 people across more than 50 countries, with over 700 staff totally focused on R&D. In 2012, Bull recorded revenues of €1.3 billion.

As an expert in delivering ultra high-power, Bull is now one of the world leaders in Extreme Computing. As an IT manufacturer, at the end of 2012 Bull had the second biggest presence in the list of the world's top 20 supercomputers, with three bullx systems: Helios, in Japan, for the international F4E (Fusion for Energy) program; CURIE, in France, for GENCI and the European PRACE initiative; and, in partnership with the CEA, Tera 100, Europe's first supercomputer to break the Petaflops barrier.

With more HPC specialists than any other player in Europe, Bull is recognized for its technological prowess, its HPC applications expertise and its ability to manage large-scale projects. bullx benefits from a major, patented innovation from Bull: direct liquid cooling, which boosts energy performance by 40%.

Across the world, numerous institutions (Météo France, SARA in the Netherlands, IT4Innovations in the Czech Republic, the German Federal Waterways Engineering and Research Institute, the Universities of Dresden, Liverpool and many others) and companies (Asco, BBVA, Dassault Aviation, Petrobras, Wirth) have turned to Bull to implement powerful, robust systems that are easy to manage and use, and are designed for round-the-clock operation. Every day, thanks to Bull, their researchers and engineers are pushing back the boundaries of the possible.

Supercalculateur bullx



Armoire bullx DLC à refroidissement liquide direct



Installation Bull au GENCI (système Curie – Courtesy of CEA-Cadarn)



CAPS ENTREPRISE

■ Stand 35

■ Contact Presse: Stéphane BIHAN,
Tel: +33 (0) 2 22 51 15 91
mail: stephane.bihan@caps-entreprise.com

CAPS entreprise is a leading provider of solutions for programming and deploying applications on parallel systems.

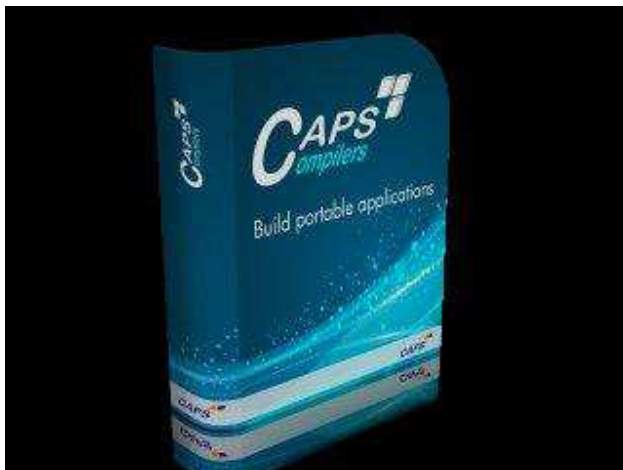

Its source-to-source compilers are based on C, C++, and FORTRAN directives and support OpenACC®.

With a strong background in programming and tuning HPC parallel machines, CAPS also provides a large range of engineering services to make your scientific applications efficiently parallel. CAPS counts many success stories in porting, optimizing and parallelizing codes in various areas: oil and gas, meteorology, biology, image processing and finance.

CAPS OpenACC compilers enable developers to incrementally build portable applications for

various many-core systems such as NVIDIA and AMD GPUs, and Intel Xeon Phi. CAPS is currently developing a new version of its compilers that will be able to process OpenMP applications for accelerators."

CCI ESSONNE

■ Stand 29

■ Contact: Marie Noëlle DECARREAUX – CCI Essonne
Tél: 06.45.97.55.29
Mail: mn.decarreaux@essonne.cci.fr

Less than a year has gone by, and 9 companies have chosen to locate in the local nursery and business hotel in Teratec Bruyères le Châtel:



Eagocom (<http://www.eagocom.com/>),
XEDIX (<http://www.visual-recognition.com/>),
Atem (<http://www.atem.com>),
Numtech (<http://www.numtech.fr>),
Alliance service plus
(<http://www.asplus.fr/Main/index.php>)
Distène (<http://www.distene.com/fr/corp/index.html>),
Scilab (<http://www.scilab.org/>),
and recently a startup, **Energy Innovation**.

In the near future the new company, fruit of the Numinov project, designed to provide intensive calculation on demand

is going to move in, this will be a real opportunity to "democratize" the access to the calculation simulator for all SMEs.

The offer of the business incubator and Teratec business hotel is designed to meet the needs of business development, from start up ... to the business development phase.

- Private areas of high standing, equipment (wired telephony), along with à la carte service giving the opportunity to choose the level of service desired: furniture, parking, reception and assistance, access to meeting rooms, pooling office resources.

In addition to these physical aspects of importance and quality, it is important to add that choosing to locate in the business hotel Teratec is to be sure to benefit from flexibility:

- The surface can be modified at any moment, even for small areas. Our premises range from 15 to 170 m²

- The lease covers only 24 months, with a possible of early termination.

Awaiting your installation, we propose a temporary office (wifi included), allowing time to accommodate any business appointments

In conclusion, tomorrow ... a strategic location at the heart of your business, think of the business incubator and business hotel Teratec

CEA

■ Stand 8

■ Contact Presse: Sylvie RIVIERE

Tel: +33 (0) 1 69 28 56 28

Mail: sylvie.riviere@cea.fr

Airain Supercomputer

CCRT (Computing Centre for Research and Technology) new supercomputer, airain, 260 TFlops peak, was opened to production in September 2012. Airain is a bullx cluster with 594 compute nodes (16 cores and 64 GB RAM each) and 200 data processing nodes (16 cores, 128 GB RAM), Intel® Xeon® E5-2680 based, interconnected by QBR Infiniband, and with 2 PB of storage.

New CCRT partners: L'Oréal and Thalès

L'Oréal and Thalès industrial partners joined CCRT in January 2013.

CCRT ten industrial members are currently: Areva, EADS/Astrium, EDF, Ineris, L'Oréal, Snecma, Techspace Aero, Thalès, Turbomeca and Valéo (2012), beside CEA four research divisions (fundamental research, nuclear energy, defence, life sciences) which also use CCRT.

These new partners joining CCRT clearly confirm CEA willingness to support industrial innovation and to promote industry/research collaboration, especially in the area of high performance numerical simulation.

CCRT: host of France Génomique data storage and processing infrastructure

France Génomique is a national project launched in 2011 by French Ministry of Research; it is coordinated by CEA Life Sciences Division Genomics Institute. France Génomique objective is to integrate national services for genome analysis and related bio-informatics data processing which are generated at very high rate, for the benefit of the four French large research organizations involved in life sciences (CEA, CNRS, INRA, INSERM). CCRT was selected to host the storage and processing infrastructure of this project. In operations since Q1 2013, up to 5 PB of data from the different partners' sequencers are being collected in this initial phase.



Crédits photo : CEA/CADAM



*Robot de stockage de la plate-forme
France Génomique au CCRT.
Crédits photo : CEA/CADAM*

EMC²

■ Stand 48

■ Contact Presse: Caroline LAVARET
Tel: 33(0)6 13 33 39 82
Mail: caroline.lavaret@emc.com

High Performance Storage for Big Data Computing

- EMC Isilon As the global leader in storage, EMC solutions are ideal for data-intensive, high performance computing (HPC) environments that require the collection, storage and transmission of large scale datasets.
- Our "best of breed" approach means that you can rely on EMC for the right storage solution to match your specific HPC application and workflow needs.
- EMC storage systems are used by thousands of organizations around the world to support incredibly intensive and demanding HPC workloads across a wide range of Big Data computing needs including:
 - Academic & Government Research
 - Business Analytics
 - Life Sciences and Genomic Research
- EMC Isilon scale-out storage solutions deliver:
 - World Record NAS Performance
 - Massive Scalability
 - Unmatched Efficiency and Ease of Use
- EMC VNX HPC series storage solutions simplify Lustre deployments and deliver:
 - Low Latency and High Throughput Performance
 - High Scalability
 - Reliable Data Protection

EMC Corporation

- EMC Corporation is a global leader in enabling organizations to transform their operations. EMC storage solutions are ideal for data-intensive, high performance computing environments that require the collection, storage and transmission of large scale datasets. Our "best of breed" approach means that you can rely on EMC for the right storage solution to match your specific high performance computing application and workflow needs. Additional information about EMC can be found at www.EMC.com.

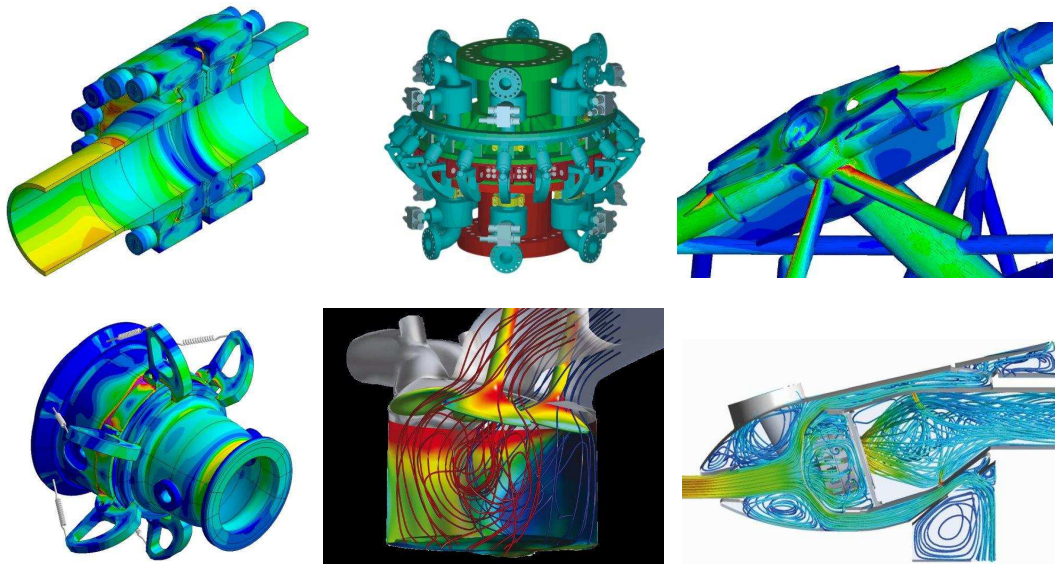

ENGINSOFT

■ **Stand 34**

■ Contact Presse: Laure RAYMOND
 Tel : +33 (0)1 41 22 99 30
 Mai: l.raymond@enginsoft.com

EnginSoft France is a premier consulting firm in the field of Simulation Based Engineering Science. We help companies identify where, when and how simulation can make a difference to their business. EnginSoft France is comprised of highly qualified engineers, with expertise in a variety of engineering simulation technologies including FEM Analysis and CFD, working in synergy with companies across the globe. EnginSoft relies on modern software solutions and operates with advanced technology calculations such as High Performance Computing (HPC).

EnginSoft France offers technical support and studies via adapted training courses. **EnginSoft France** also focuses on research and development by participating in competitiveness pole projects. By doing so, we reinforce our position as leader in the domain of numerical simulation solutions.

modeFRONTIER® is the only independent software for optimization, multi objective and multidisciplinary design. The ease of integration of CAE tools especially CFD codes makes modeFRONTIER® an essential tool for manufacturing processes. Its main benefits such as statistics analysis, data mining, decision support tools, optimization and ease of interfacing significantly improve design performance.

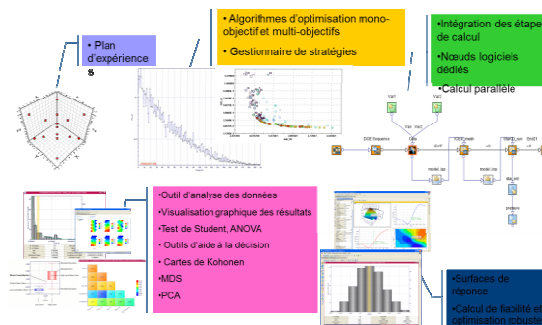
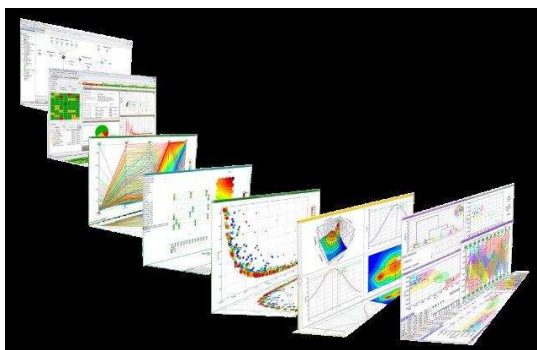

Flowmaster® is a fluid system simulation software based on a user-friendly graphic interface and on a relational data base including over 400 components (valves, pumps, heat exchangers ...). It enables all types of steady state and transient analysis with or without heat transfer for any fluids. It offers users the possibility to size their network. Its large flexibility and its integration tools give Flowmaster® a leading position in its domain.

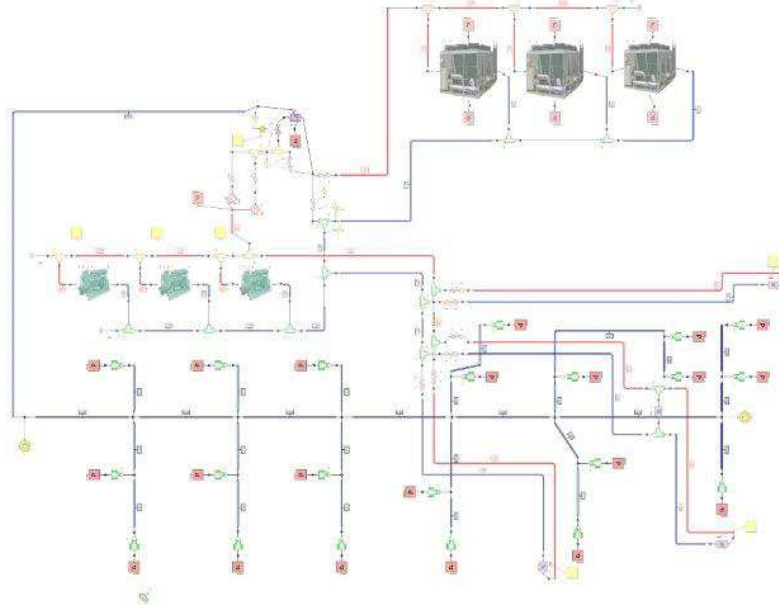

CharLES® is a 3D CFD code able to perform combustion, aeroacoustic and multiphase calculations using LES method (Large Eddy Simulation). Resulting from the collaboration between Cascade Technology (a spin off of Stanford University – Pr Moin) and EnginSoft, CharLES® has several advantages:

- The performance of its resolution schemes makes it possible to minimize numerical dissipation and consequently to increase precision.
- The high parallelization of the code ensures increasing scalability (>16000 cores).
- The compatibility with the display of the commercial meshes softwares guarantees also an immediate integration of the tool.

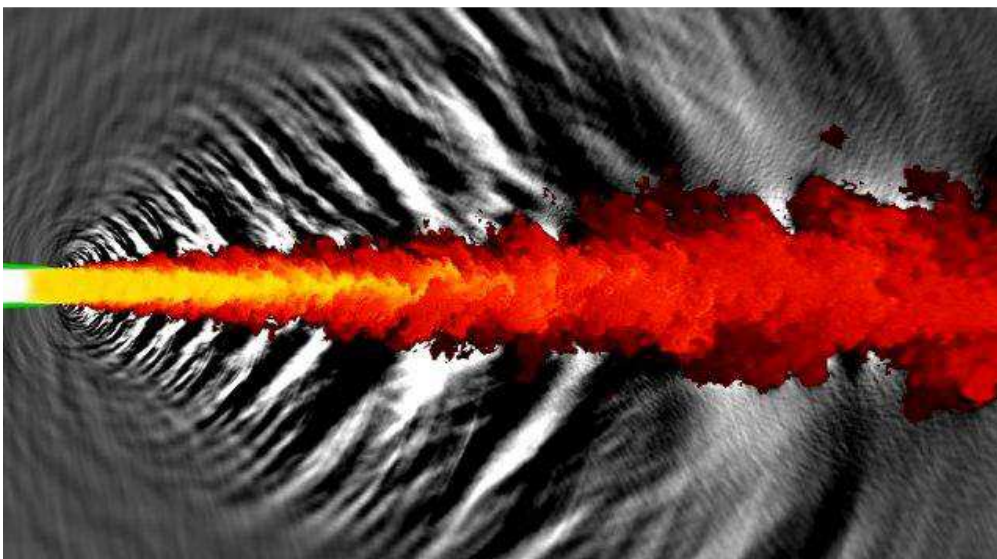

■ Contact Presse: Giovanbattista Mattiussi
Marketing Manager HPC
Tel: +39 0433 485467 / Mobile: +39 345 7153193
Mail:

Eurotech is a global listed company based in Italy, with subsidiaries in Europe, North America and Asia. The Eurotech Group develops and markets miniaturized computers and high performance computers. With these two product categories Eurotech aims to become a leader in the implementation of the pervasive computing scenario which, by exploiting the Cloud IT infrastructure, is capable of enabling an entire range of value-added activities and services.

The Eurotech HPC division has more than 15 years of experience in manufacturing HPCs and delivering HPC solutions. Eurotech supercomputer line, Aurora, offers a range of advanced, hot water cooled, ultra dense, green HPC systems. Aurora supercomputers are designed to excel in energy efficiency, footprint, reliability and performance. With direct liquid cooled with hot water, hot swappable blades, modular and scalable architecture built on standard commercial components, the Aurora supers offer optional FPGA and 3D torus boards to maximize functionality, performance and efficiency.

Eurotech is at the forefront of research projects, like DEEP (dynamic exascale entry platform) and others, that look into the future with exascale solution leveraging GPU and MIC architectures. Funding and board member of the ETP4HPC, Eurotech believes that a strong European HPC value chain not only can increase European competitiveness but also can bring benefit to the world.



■ Contact Presse: Mimiti TARDIF
Assistante Chef de Marché Infrastructure
Tel: +33 (0) 1 41 97 90 13
Mail: contact.france@ts.fujitsu.com

Fujitsu launched recently a high performance, high expandability, high reliability, and low power consumption, supercomputer called "PRIMEHPC FX10,"



This product is a further enhanced version of the Fujitsu supercomputer technology employed in the "K computer"; which achieved world top-ranked performance in Nov 2011.

"PRIMEHPC FX10 is a world-class, high-speed, ultra-large-scale computing environment scalable up to 23.2 petaflops.

Maximum configuration consists of 98,304 nodes, 1,024 racks, and 6 petabytes of memory. Such a configuration would deliver a high-speed, ultrascale computing environment with a theoretical computing performance of 23.2 petaflops.

A complete stack of integrated and certified ready-to-go HPC cluster solutions based on x86 PRIMERGY servers, and software including SynfiniWay, a cloud software platform, will be highlighted at TERATEC.

Fujitsu has a variety of computing products such as multi petaflops class supercomputer, x86-based HPC cluster, software and solutions to meet comprehensive technical computing requirements.

INTEL EXASCALE COMMUTING RESEARCH LAB

■ Stand 24

■ Contact Presse: Marie-Christine SAWLEY

Tel: +33 (0) 6 0 38 14 41

Mail: marie-christine.sawley@intel.com

The French Exascale Computing Research (ECR) Lab has been the first exascale lab established by Intel in Europe in 2010, as a shared effort between the partners CEA, GENCI, the University of Versailles-St-Quentin-en-Yvelines, and Intel. It focuses on:

Application enabling co-design. The areas of study encompass programming models for high scalability, data flows, and numerical performance.

The purpose is to analyze selected applications with their full complexity, assess their behavior on prototypes of future architectures, and work in close collaboration with the developer to increase application efficiency as well as current and future scalability.

The methodology for performance evaluation developed at the lab is central to these activities. In 2012 the efforts were focused on Geosciences and Molecular Dynamics, working on higher efficiency on production HPC systems and preparing for increased scalability on Intel MIC architecture.

- Software tools and middleware to characterize applications and optimize their performance on future exascale machines. The work will allow developers to improve scalability, performance, resource saturation and power consumption of their parallel applications. It will also help hardware designers and compiler builders optimize their products. Three main topics are being studied:
 - Programming models and runtime systems
 - Performance tools and a methodology to help users identify performance problems quickly and evaluate potential optimization gains
 - Application characterization framework, analyzing the hot code segments and deriving optimization recommendations and performance predictions.

The lab is active with French industry and academic partners and participates to education through training and dissemination programs. It is also very focused on world class exascale challenges and therefore interacts with a number of European partners.

IRT SYSTEMX

■ Stand 23

■ Contact Presse: Virginie BOISGONTIER, Responsable Communication

Tél: +33 (0) 1 69 81 65 61 – +33 (0) 7 86 75 02 97

Mél: Virginie.boisgontier@irt-systemx.fr

Getting Started with the R&D SystemX projects

The signature of the agreement with the French National Research Agency (ANR) took place last October 31st and formalized the official launch of the Research Institute of Technology SystemX. SystemX kick-off event has been organized February 21st, 2013 on its main site in Palaiseau in the NanoInnov buildings.

The first partnership agreements with SystemX enable the start of the R&D projects with teams collocated in NanoInnov buildings in Palaiseau, in the EIT ICT and LINCS labs in Paris and on the Teratec Campus in Bruyères-Le-Chatel.

The Teratec Campus in Bruyères-Le-Chatel has been selected to host SystemX project teams working on the theme of High Performance Computing (HPC).

For example, the Extreme Computing project, gathering partners such as Bull or CEA research center, aims at reaching exascale performance focusing on architecture dimensioning, analysis of end-users needs, input/output and systems management. Another example is the project entitled Parallel Algorithms and Remote Access Technology led by OVH.COM, ESI Group, ECP and UVSQ. In this case, the aim is to study scientific and engineering principles and standards in order to develop an efficient next-generation

computer simulation environment: fully unified, automated, secure and available remotely.

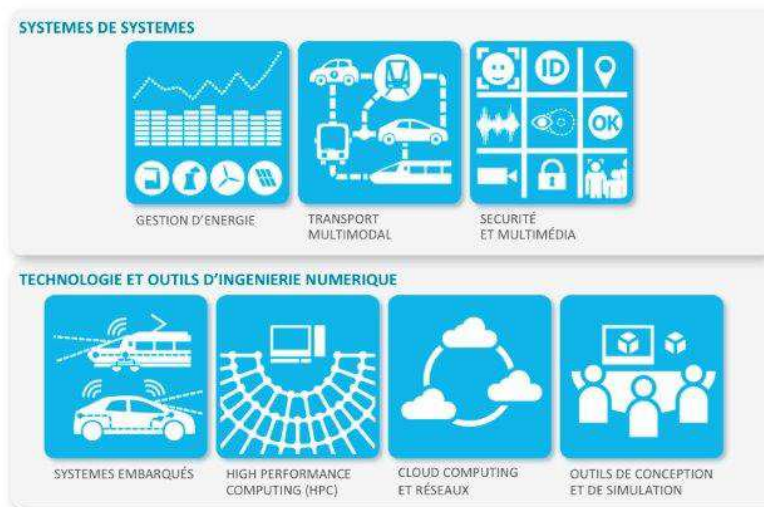

By having a combination of major industrial players and young technology companies present on the TERATEC site, covering the entire field of computing and simulation, we will be able to go much further toward mastering these technologies and take the steps required for these technologies to spread throughout every sector of the economy (transport, communications, digital security and energy).

KALRAY

■ Stand 10

■ Contact Presse: Laurent JULLIARD, Director of Solutions and Software Services

Tel: + 33 6 73 78 04 38

Mail: laurent.julliard@kalray.eu

KALRAY is a fabless semiconductor & software company selling the MPPA MANYCORE, a family of new generation processors offering high processing capabilities at low power consumption, along with C/C++-based programming models.

These products boost the development of innovative digital applications in the fields of intensive computing, telecommunication, image & signal processing, medical and embedded systems.

The first MPPA MANYCORE chip, the MPPA 256 integrates 256 compute cores, delivering more than 700 GOPs/230 GFLOPs with a typical 5W power consumption.

It opens the door to a new class of intensive computing systems thanks to its innovative scalable architecture. Indeed, the MPPA MANYCORE allows to cluster thousands of cores with a big memory capacity while still having low energy requirements.

KALRAY also provides the MPPA DEVELOPER, a ready-to-use development platform including MPPA ACCESSCORE SDK, a unified software tool allowing users to program HPC applications that will be

ultimately executed in parallel across a host processor and multiple MPPA MANYCORE chips, delegating the complexity of the partitioning to the compiler.

NETAPP

■ Stand 41

■ Contact Presse: Thierry PAPROCKI, Sales Manager
Tel: +33 (6) 15 02 07 30
Mail: Thierry.Paprocki@netapp.com

The NetApp® High-Performance Computing Solution for efficient Parallel File System is purpose-built to efficiently scale bandwidth and density with uncompromised reliability, solving difficult research, modeling, and simulation problems.

Based on the NetApp E-Series storage platform and high performance file system (IBM's GPFS, Intel's

Lustre, Quantum's Stornext,..), it offers an infrastructure that is designed for the flexibility, performance, and scalability required by the most demanding workflows to meet storage requirements today and in the future:

- Proven performance. Delivers a dramatic increase in throughput and I/O, allowing massively parallel file access.
- Excellent scalability. Scales to tens of petabytes of data and tens of thousands of clients.
- Reliability. Meets uptime requirements of both business and research applications.
- Decreased costs. Significantly reduces deployment and support costs with preconfigured and pretested configurations.

The NetApp solution is designed and optimized for the most demanding data-processing workloads. The pre-configured, pre-tested solution supports the high bandwidth and density required to capture and share large datasets across multiple

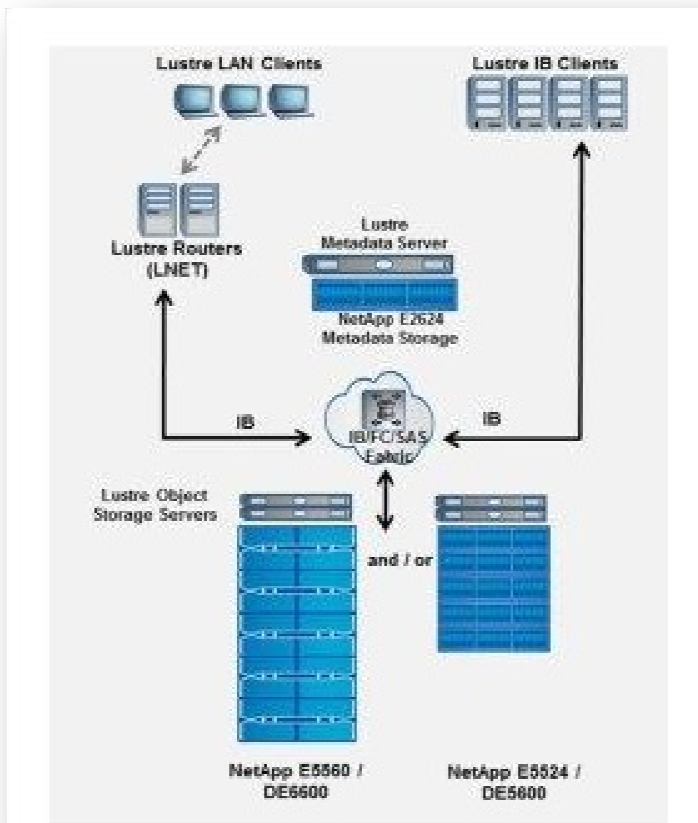

applications and sites.

System configurations can easily be expanded to address growing capacity needs for years to come:

- Big bandwidth support. Supports 240TB in just one 4U, or up to 2.4PB in each industry-standard 40U rack.
- Modular design. Allows growth with minimal components, eliminating the need to over configure.
- Extreme flexibility. Scale bandwidth and capacity independently. Start small and expand in 2U or 4U increments.

- Fast time to deployment. Bundled with NetApp Professional Services installation to accelerate time to production.

NICE SOFTWARE

■ Stand 40

■ Contact Presse: Douglas MCKINLEY
 Tel: + 39 34 03 19 59 68
 Mail: douglas.mckinley@nice-software.com

NICE delivers Technical Cloud Products and Solutions, to worldwide customers, boosting productivity, saving money on IT and enabling faster design cycles and collaboration.

NICE helps centralizing, optimizing and consolidating HPC and visualization resources while empowering distributed and mobile Engineering workforces to run batch and interactive applications anywhere, with any client. NICE also allows engineering teams around the world to collaborate by sharing application sessions over standard networks.

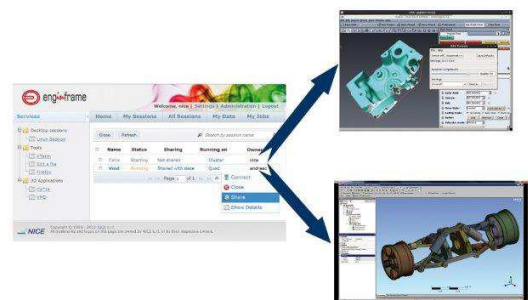

NICE EnginFrame, NICE's HPC portal offering, is an advanced, commercially supported grid portal that provides access to grid-enabled infrastructures, HPC clusters, data, licenses, and interactive applications. It can be accessed by any authorized user with a standard web browser.

EnginFrame deftly handles computational-intensive, control, and monitoring. EnginFrame is based on standard protocols that facilitate the deployment of engineer-friendly portals to create, discover, and explore more efficiently.

NICE Desktop Cloud Visualization (DCV), NICE's remote 3D "virtual workstation" offering, is an advanced remote 3D access technology that allows technical end users to access robust 3D modeling tools through a web-based portal.

IT professionals can share GPUs and memory across multiple user sessions. Data resides securely in the data center, reducing load time and offering IT professionals the option of granting data and application access based on the user's needs."



■ **Contact Presse:** Stephane QUENTIN
Senior PR Manager France & Belgium
Tel: +33 (0) 1.556.38493
Mel: squentin@nvidia.com

NVIDIA will be featuring advances in applications and scientific discovery made with GPU-accelerated computing. NVIDIA Tesla K-series GPU Accelerators are based on the NVIDIA Kepler compute architecture and powered by CUDA, the world's most pervasive parallel computing model. They include innovative technologies like Dynamic Parallelism and Hyper-Q to boost performance as well as power efficiency and deliver record application speeds for seismic processing, biochemistry simulations, weather and climate modeling, image, video and signal processing, computational finance, computational physics, CAE, CFD, and data analytics.

At the NVIDIA booth, there will be opportunities to discuss the latest achievements using GPU technologies in accelerated computing, as well as taking a look at how GPUs are being used to advance scientific discoveries.

In addition, the plenary sessions will see NVIDIA present "The Era of Accelerated Computing" and our partners PNY Technologies and Carrie will feature the new ARM-based HPC development platform Kayla, combining a Tegra-based Quad-core ARM CPU with a Kepler GPU, delivering the highest performance with highest efficiency for the next generation of CUDA and OpenGL applications. Kayla supports CUDA 5.5 and OpenGL4.3 and provides ARM application development across the widest range of application types.



NVIDIA Tesla K20 GPU accelerator



Kayla development platform

■ Contact Presse: Jean-Marie Davesnes, Innovation Marketing Manager

Tel: +33 (0)1 49 58 45 70

Mail: jean-marie.davesnes@oxalya.com

★★★ In first preview: Spotlight on HPCSpot

First product of the partnership between Oxalya, leader in High Performance Computing (HPC), and OVH, Europe's number one in web hosting services, HPCSpot has been officially launched in June 2013.

Benoît Vautrin, COO of Oxalya, details a preview of the main strong points of this original solution of Cloud HPC.

What are the applications of HPCSpot?

In a context of increased competitiveness, companies need to shorten their time to market and decrease their costs. We have designed HPCSpot as a solution that enables to make the access to numerical simulation easier, which is more accessible than a prototype development and accelerates the conception cycle. One of the major advantages of this offer is that it covers all fields of use of HPC, from fluid dynamics to structure computations, including thermal computations as well as molecular chemistry. During the design of a car, for example, HPCSpot can be used from the development of a simple windshield wiper blade to the simulation of a crash-test.

Whom does HPCSpot address?

Our solution addresses all the companies that wish to get their costs under control, despite fluctuating simulation needs. We know that depending on their project agendas, those needs can be subject to wide variations when it comes to material or software resources. HPCSpot provides a real solution to this issue by replacing heavy investments (CAPEX) with the flexibility of leasing of resources on demand (OPEX) and this, without having to recruit specialists in high performance infrastructures management.

The screenshot displays the HPCSpot web interface. At the top, there is a navigation bar with tabs for Home, Jobs, Sessions, Datasets, TAG, and Administration. Below the navigation bar, a welcome message is shown for Jean-Marie Davesnes, followed by a list of features and a list of applications. On the right side, there are three buttons: 'Submit a new job', 'New graphical session', and 'Expert Mode'.

Home **Jobs** **Sessions** **Datasets** **TAG** **Administration**

Welcome Jean-Marie Davesnes

Welcome Jean-Marie Davesnes to work out, prepare and visualise your results. We provide to you a rich, powerful and easy HPC hardware and software environment.

Ease of use: you love web interfaces:

1. use the **Datasets** tab to manage / access to your files
2. use the **Jobs** tab to start processing jobs
3. use the **Sessions** tab to start graphical session and access graphical programs. You will benefit of the video acceleration of the remote graphical machine.

you prefer command line interfaces:

1. you can copy your files with `scp`.
2. you can launch jobs with `ssh / srun / sbatch`.

Powerful: powerful processing nodes:
powerful graphical machines

Rich: Your software are ready to run.

Where to begin?
Go check out our **Computational Fluid Dynamics Tutorial** that will walk you through a full OAS HPC platform/Paraview workflow on HPCSpot. This tutorial does not require any previous knowledge about the software, HPCSpot features can be used with other softwares.

Here the list of applications that we offer

- LaBS** LaBS 1.8.605
LaBS Solver graphical interface
- Paraview** Paraview 3.14 default
Paraview is an open-source, multi-platform data analysis and visualization application. Paraview users can quickly build visualizations to analyze their data using quantitative and qualitative techniques. The data exploration can be done interactively in 3D or programmatically using Paraview's batch processing capabilities. This version can use parallelization on HPCSpot.
- Paraview** Paraview 3.14 vanilla
Paraview is an open-source, multi-platform data analysis and visualization application. Paraview users can quickly build visualizations to analyze their data using quantitative and qualitative techniques. The data exploration can be done interactively in 3D or programmatically using Paraview's batch processing capabilities. This is the unmodified official Paraview binary version.

Submit a new job

New graphical session

Expert Mode

What are the specific features of this solution?

First of all, our customers benefit from physical machines that are specifically designed for scientific computing and visualization and not from mainstream virtualized infrastructures that are traditionally to be found in the SaaS. All the machines are interconnected with a low-latency network and have a secure remote access. Another characteristic is that we take into account the whole regular numerical simulation chain (modeling, data preparation, computing, result processing) while concealing the complexity of such an infrastructure. Last but not least, the whole solution of HPCSpot is hosted in a data center located in Europe, in Roubaix (France).

How can one use HPCSpot?

HPCSpot is available on demand, on a pay-per-use basis, in order to address the users' needs of flexibility. The pricing is clear and published on our website. Then, depending on his project constraints, the customer can choose between the utilization of a catalogue of pre-integrated software (SaaS mode) or a dedicated cluster (PaaS mode). Finally, HPCSpot doesn't require any installation on the user's desktop since the whole offer is directly accessible from a web browser.

How does this offer take advantage of the expertise of Oxalya and OVH?

This first offer combines the reputed know-how of OVH in the fields of Cloud Computing and server hosting with our solid proficiency in High Performance Computing, in which we are specialized in since 2005. The synergy of both our expertises enables us to propose those turnkey offers at the best price.

QUANTUM

■ Stand 2

■ Contact Presse: Laurent FANICHET
Product Marketing Manager EMEA – Big Data
Tel: +33 1 41 43 49 00
Mail: Laurent.fanichet@quantum.com

Quantum's Big Data solutions dedicated to the Scientific Community

From seismic analysis to meteorological data and satellite imaging, scientific and research companies need to process larger and larger sets of data quickly and retain it securely. But they also need to reduce storage costs and protect revenue-generating digital assets. That's why organizations around the world rely on Quantum StorNext data sharing and archiving solutions that will be showcased during Teratec 2013.

Store, Manage and Archive Your Growing Volume of Scientific Data with Quantum StorNext

- **Store** – **Quantum StorNext** is the real-time storage enabler that helps scientific and research organizations, like CERN in Switzerland, achieve high-performance digital content ingest.
- **Share** – **Quantum StorNext** has great shared collaboration and shared file system capabilities to manage and share scientific data across multiple platforms and multiple tiers of storage (disk, object storage, tape and cloud)
- **Archive** – Quantum's **Lattus** next generation object storage platform and Quantum's **StorNext AEL Archive appliances** solutions help you preserve your scientific and research data for decades and more at the best possible costs.

During Teratec 2013, come and discover Quantum **StorNext**, its high-performance file sharing and archiving solutions and the newly releases appliances : disk-based object archiving platform, high-performance disk storage systems and a large portfolio of LTO tape libraries for long term retention.

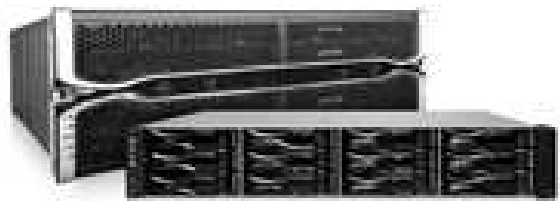

■ Contact Presse: Julie PAUL, Communication and public relations Director
Tel : +33 (0)1 80 77 04 79
Mail : julie.paul@scilab-enterprises.com

Founded in June 2010, Scilab Enterprises is the official publisher and professional services provider of Scilab software.

Scilab software, stemming from Inria, is the worldwide open source reference in numerical computation and simulation software.

Scilab is used in all major strategic scientific areas of industry and services such as space, aeronautics, automotive, energy, defense, finance and transport.

Scilab Enterprises is committed to providing expertise in the implementation of optimal solutions in terms of technological innovation and helping companies to make the right decisions in computation and simulation tools. Scilab Enterprises advises companies by offering a comprehensive range of support, training, migration, development and implementation of specific applications in their technology environments.

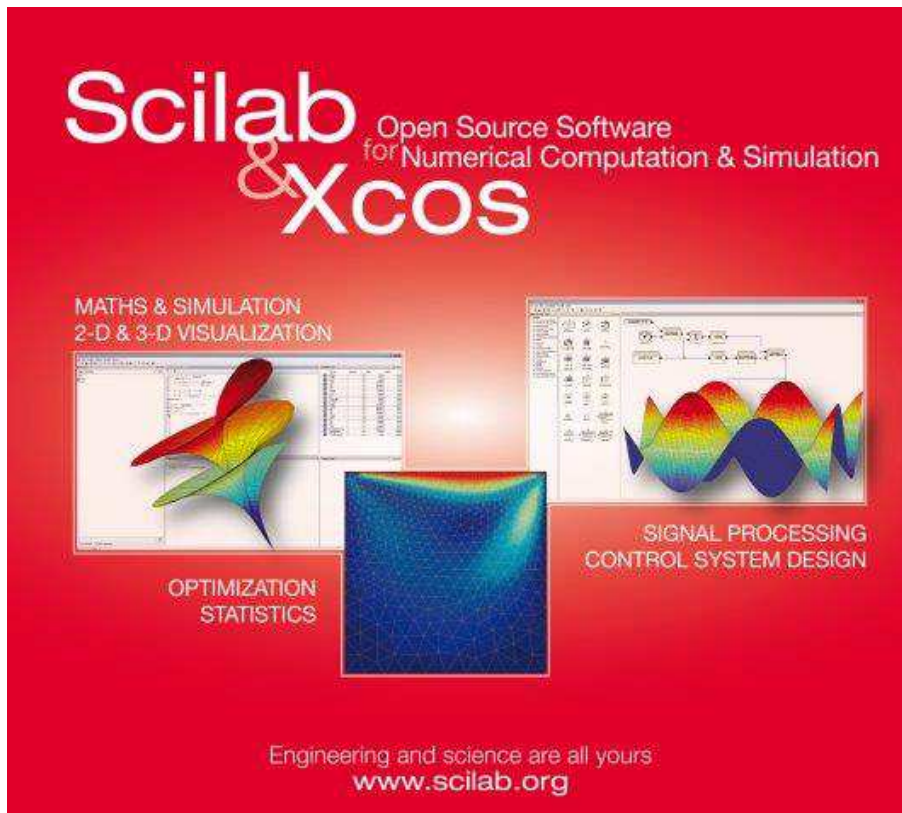

The image is a promotional graphic for Scilab & Xcos. It features a red background with the text "Scilab & Xcos" in white, where "&" is a stylized ampersand. To the right of the logo, it says "Open Source Software for Numerical Computation & Simulation". Below the logo, there are four panels illustrating different capabilities: "MATHS & SIMULATION 2-D & 3-D VISUALIZATION" with a 3D surface plot, "OPTIMIZATION STATISTICS" with a 2D heatmap, "SIGNAL PROCESSING CONTROL SYSTEM DESIGN" with a 3D surface plot and a block diagram, and a central 3D heatmap. At the bottom, it says "Engineering and science are all yours" and "www.scilab.org".

Scilab & Xcos Open Source Software for Numerical Computation & Simulation

MATHS & SIMULATION
2-D & 3-D VISUALIZATION

OPTIMIZATION
STATISTICS

SIGNAL PROCESSING
CONTROL SYSTEM DESIGN

Engineering and science are all yours
www.scilab.org

■ Contact Presse: Patrice GOMMY
 Tel: +33 (0) 1 34 88 80 12
 Mail : pgommy@sgi.com

SGI® InfiniteStorage™ Gateway, Leveraging proven technology to reduce the runaway cost of online data access and protection.

SGI InfiniteStorage Gateway reduces the dependency on high-cost primary storage by creating a virtualized storage fabric that can include any mixture of disk, tape, Zero-Watt Disk or MAID, and object storage.

The system automatically places data on any or all storage devices and locations based upon what works best for the access requirements and data protection policies.

By seamlessly connecting to existing heterogeneous storage environments, SGI InfiniteStorage Gateway provides a way for users to see and access all the data all the time, no matter what might be happening to the storage infrastructure in the background. Because the storage infrastructure is virtualized, as requirements change, the type of storage deployed can also evolve, with no interruption to users.

SGI InfiniteStorage Gateway includes up to 276TB of onboard capacity in a single 4U appliance. As that local capacity begins to fill, data is virtualized with any of multiple different storage choices to enable the entire storage fabric to scale to massive proportions.

SGI InfiniteStorage Gateway bundles into an easy-to-deploy appliance [SGI® DMF™](#) technology, the tiered virtualization software SGI has deployed in hundreds of customers worldwide in some of the industry's most demanding data management environments.

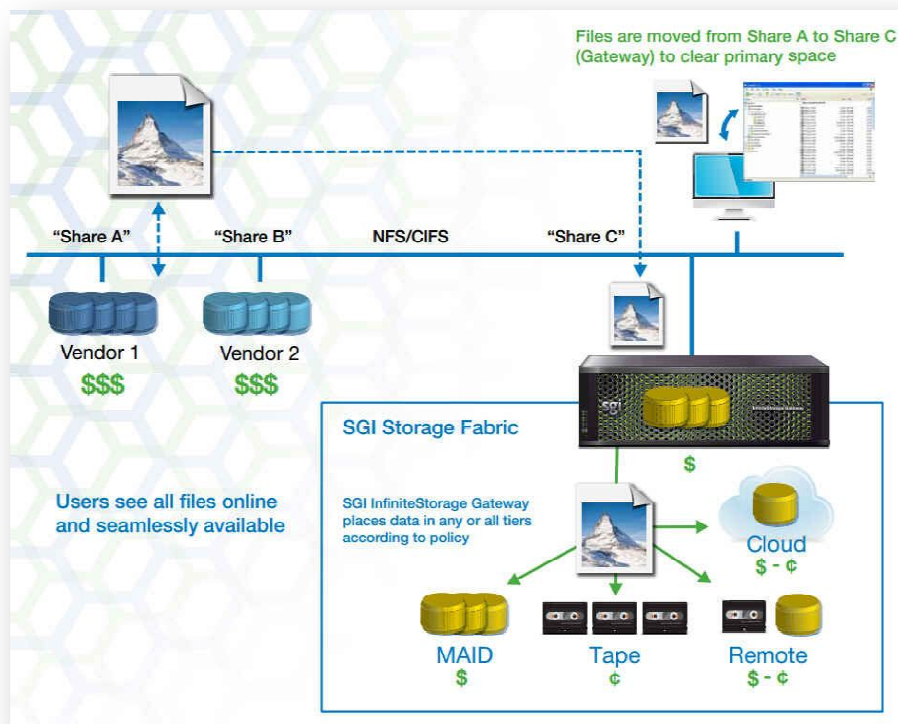

■ Contact presse: Augustin RAGON
Tel 04.81.76.28.94
Mail : augustin.ragon@sysfera.com

***** In first presentation, SysFera unveils the latest versions of its flagship products:**

SysFera-DS WebBoard, the solution for easier usage of computing and visualization resources.

This collaborative portal covers the entire workflow of engineers and specialists: data management, applications (graphical or batch), post-processing. It enables unified access to, and reservation of, computing and visualization resources. No client-side installation is required: it is accessible from any modern web browser and offers a responsive interface.

A major asset to system and network administrators, it is non-intrusive (runs in the userspace, no network ports to open), non-exclusive (resources remain accessible through other means), and secure (end-to-end authentication, integration with user-management systems, encrypted communications).



UcanSaaS, the modular solution for porting and marketing desktop or web applications as SaaS.

Independent Software Vendors now have a way to quickly offer their applications as-a-Service, which requires neither heavy R&D costs nor having to manage computing resources, be they their own or deployed in the Cloud.

Once installed, UcanSaaS allows defining business models for the applications, and commercializing them. Plugins are available to add features such as customer relationship, sales, billing, usage tracking and more.

Thanks to UcanSaaS, ISVs have a simple and fast solution to access new market segments and reach an international audience!



■ Contact Presse: Vincent PFLEGER, Country Manager
 Tel : +33 (0) 3 88 55 16 27
 Mail : vpfleger@transtec.fr

**How do I benefit from the most powerful HPC system if I cannot administrate it?
 "High performance and ease of management. That's what a transtec solution is all about."**

Every transtec solution is more than just a rack full of hardware -- it is a comprehensive solution with everything the HPC user, owner, and operator need. transtec HPC clusters are ready-to-run systems -- we deliver, you turn the key, the system delivers high performance.



transtec Services do not stop when the implementation projects ends. transtec offers a variety of support and service options, tailored to the customer's needs. When you are in need of a new installation, a major reconfiguration or an update of your solution -- transtec is there to do it for you.

From Professional Services to Managed Services for daily operations and required service levels, transtec will be your complete HPC service and solution provider. transtec's high standards of performance, reliability, and

dependability assure your productivity and complete satisfaction.

